



# Compressed Air Treatment

**Compressed air treatment diagrams for rotary screw compressors**  
The perfect treatment components for every application

# Installation recommendations for pure compressed air

Compressed air treatment with a refrigeration dryer (pressure dew point to +3 °C)

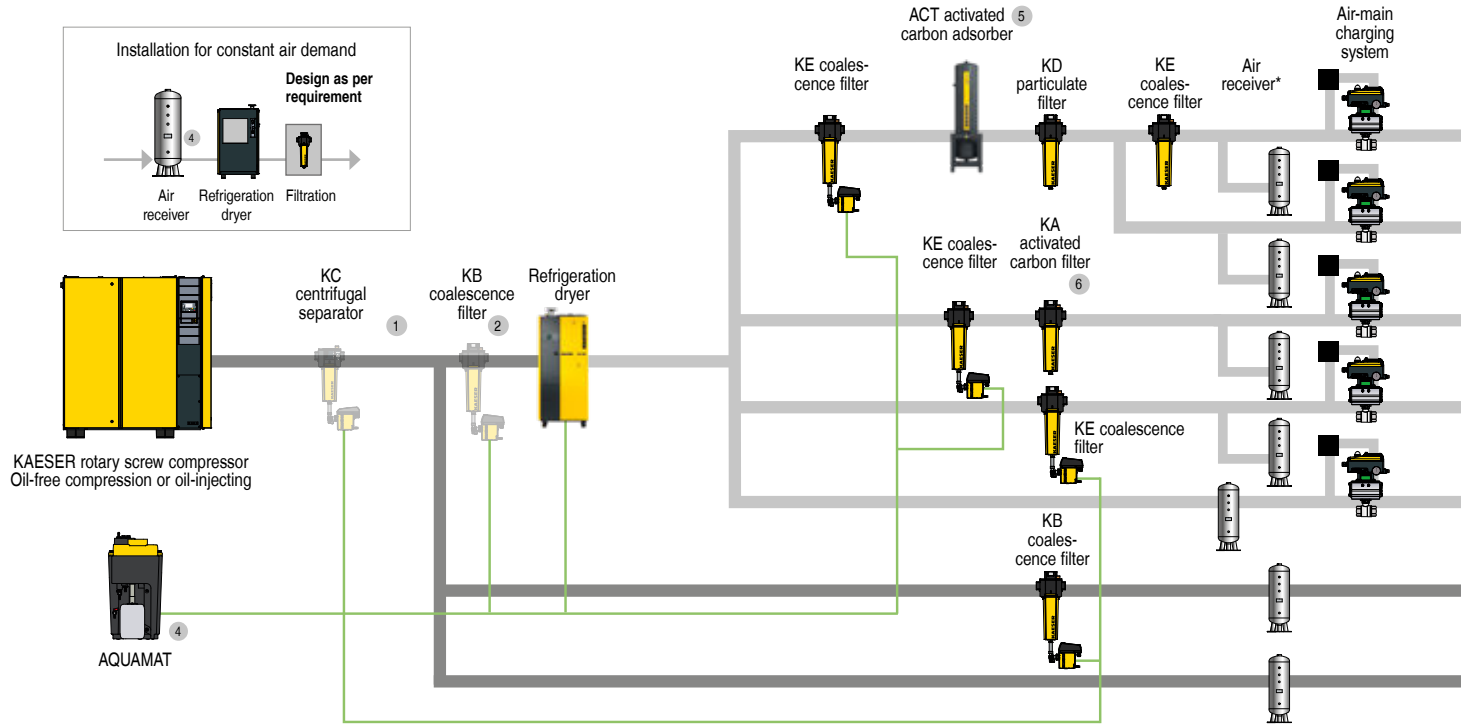

Compressed air treatment with a desiccant dryer (pressure dew point down to -70 °C, e.g. for applications subject to sub-zero temperatures)

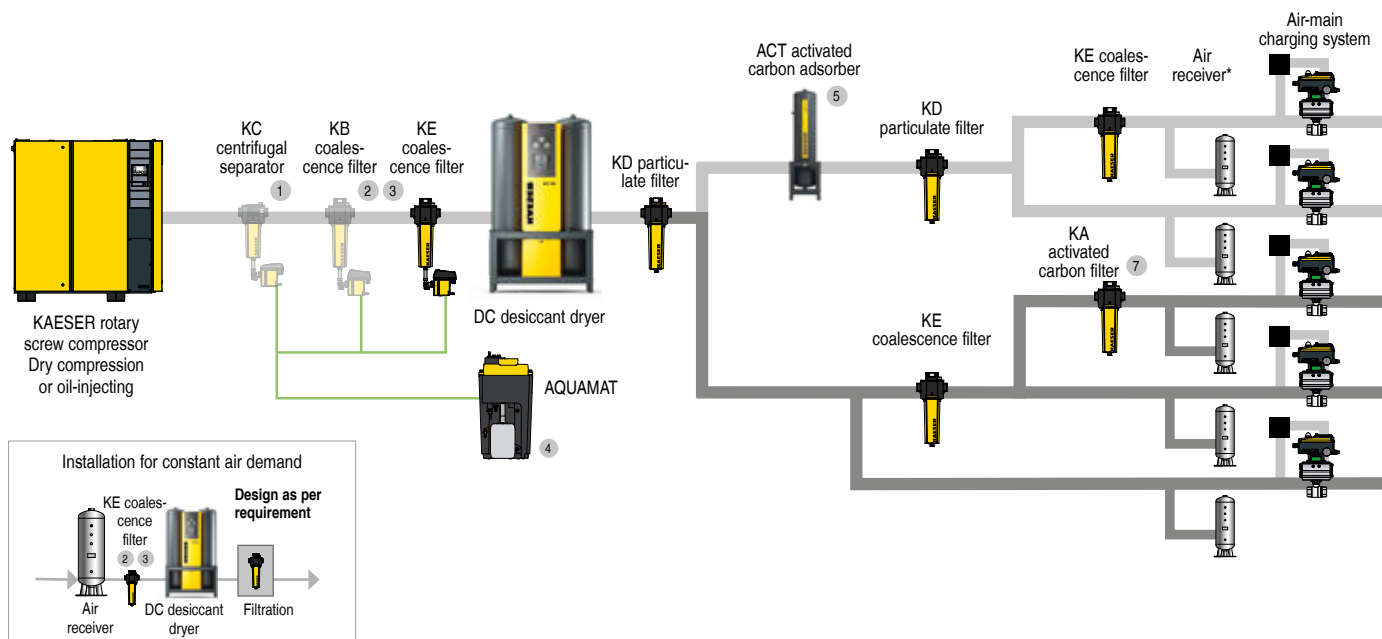

- ① No KC required in compressors with integrated centrifugal separator.
- ② KB filter installed upstream for third-party compressors or contaminated / highly corroded pipework.
- ③ KB filter installed upstream for critical applications requiring compressed air with a high level of purity.
- ④ With oil-free compression rotary screw compressors, condensate must be disposed of at the user-end.

- ⑤ Service life approx. 12,000 h
- ⑥ Service life approx. 500 h
- ⑦ Service life approx. 1,000 h
- ⑧ Dependent on cooling temperature

**Choose the required grade of treatment according to your field of application:**

Application examples: Selection of compressed air treatment classes as per ISO 8573-1 (2010)

**Achievable compressed air purity class**

**Sector/Application**

Particulates	Water	Oil
1	4	1
2	4	1
1	4	1
1	4	2
4	4	3
4	7-X <sup>8</sup>	3
4-6	7-X <sup>8</sup>	3-4

Pure air and clean-room technology, dairies, breweries, food production
Especially clean conveying air, chemical plants
Weaving machines, photo labs, pharmaceuticals industry
Paint spraying, powder coating, packing, control and instrument air
General works air, high-grade sandblasting
Shot-blasting
Conveying air for wastewater systems

**Compressed air quality classes as per ISO 8573-1 (2010):**

Particulates			
Class	Max. particle count of size d [µm] per m <sup>3</sup> *)		
	0.1 < d ≤ 0.5	0.5 < d ≤ 1.0	1.0 < d ≤ 5.0
0	Consult KAESER, e.g. regarding pure air and clean-room technology		
1	≤ 20,000	≤ 400	≤ 10
2	≤ 400,000	≤ 6,000	≤ 100
3	Not defined	≤ 90,000	≤ 1,000
4	Not defined	Not defined	≤ 10,000
5	Not defined	Not defined	≤ 100,000
Class	Particulate concentration C <sub>p</sub> in mg/m <sup>3</sup> *)		
6	0 < C <sub>p</sub> ≤ 5		
7	5 < C <sub>p</sub> ≤ 10		
X	C <sub>p</sub> > 10		

**Achievable compressed air purity class**

**Sector/Application**

Particulates	Water	Oil
1	1-3	1
2	1-3	1
1	1-3	1
1	1-3	2
2	1-3	2

Pure air and clean-room technology, pharmaceuticals industry, food production
Paint spraying installations
Process air, pharmaceuticals industry
Photo labs
Especially dry conveying air, paint spraying, fine pressure controllers

Water	
Class	Pressure dew point, in °C
0	Consult KAESER, e.g. regarding pure air and clean-room technology
1	≤ -70 °C
2	≤ -40 °C
3	≤ -20 °C
4	≤ +3 °C
5	≤ +7 °C
6	≤ +10 °C
Class	Concentration of liquid water C <sub>w</sub> in g/m <sup>3</sup> *)
7	C <sub>w</sub> ≤ 0.5
8	0.5 < C <sub>w</sub> ≤ 5
9	5 < C <sub>w</sub> ≤ 10
X	C <sub>w</sub> > 10

Oil	
Class	Total oil concentration (liquid, aerosol + gaseous) [mg/m <sup>3</sup> ] *)
0	Consult KAESER, e.g. regarding pure air and clean-room technology
1	≤ 0.01
2	≤ 0.1
3	≤ 1.0
4	≤ 5.0
X	> 5.0

\*) At reference conditions +20 °C, 1 bar(a), 0% humidity.

\* Where compressed air quality requirements are high, the air receiver should always be installed in a branch line after the treatment systems, in order to prevent deposits from being conveyed with the compressed air.

# The world is our home

As one of the world's largest manufacturers of compressors, blowers and compressed air systems, KAESER KOMPRESSOREN is represented throughout the world by a comprehensive network of wholly owned subsidiaries and authorised distribution partners in over 140 countries.

By offering innovative, efficient and reliable products and services, KAESER KOMPRESSOREN's experienced consultants and engineers work in close partnership with customers to enhance their competitive edge and to develop progressive system concepts that continuously push the boundaries of performance and technology. Moreover, decades of knowledge and expertise from this industry-leading systems provider are made available to each and every customer via the KAESER group's advanced global IT network.

These advantages, coupled with KAESER's worldwide service organisation, ensure that every product operates at the peak of its performance at all times, providing optimal efficiency and maximum availability.



## KAESER KOMPRESSOREN SE

P.O. Box 2143 – 96410 Coburg – GERMANY – Tel +49 9561 640-0 – Fax +49 9561 640-130  
E-mail: [productinfo@kaeser.com](mailto:productinfo@kaeser.com) – [www.kaeser.com](http://www.kaeser.com)